

# Charger Electric Model HLE



## Rugged.... Durable.... Harlan



### Standard Features

- High Efficiency AC Motor allows for longer duty cycles between charges
- AC Pump Motor
- Keyless or Keyed master Switch
- Two LED Headlights and turn signals
- Combination LED Tail/Stop Lights & Back-up Light
- Safety kill switch on driver's seat
- LCD Dash Display
- Fwd & Rvs Inching
- Standard Driver and Passenger seat
- Retractable Seatbelts
- Rear Mount E-Hitch

Available with Lithium-ion or Lead-acid, the Harlan Model "Charger HLE" is equipped to handle all your light duty baggage and cargo needs. The low maintenance electric package is designed for easy access to all major components.

By adding the push-back package this unit can also be utilized for push-back of regional jets up to 100K (45359kg). Some options include: complete cab assembly, heat/defrost, mirrors, beacons, variety of hitches and suspension style seats.



# Specifications

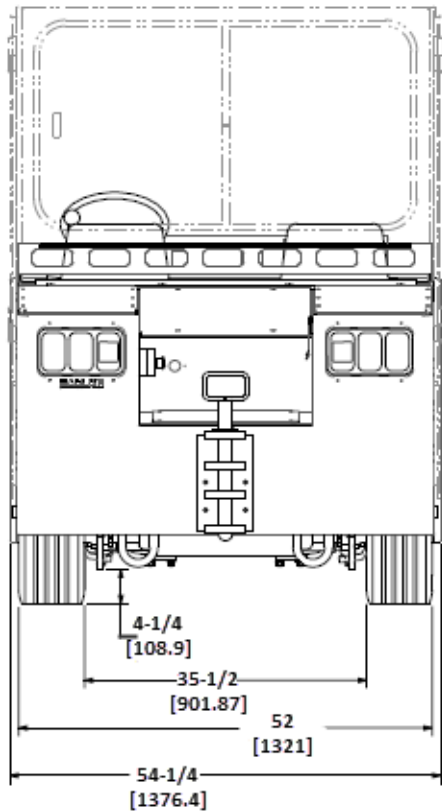

## Length

116.28" (2953 mm)  
w/ rear hitch: 122" (3099 mm)

## Width

52" (1321 mm)  
w/ Cab: 54.25 (1376 mm)

## Height

52" (1321 mm)  
w/ Cab 75.28" (1930 mm)

## Wheel Base

64.25" (1632 mm)

## Ground Clearance

7.25" (184.5 mm)

## Integrated Drive Axle

Fully integrated with AC Induction Motor

## Service Brakes

**Primary:** 4-Wheel Hydraulic

**Secondary:** Traction motor braking with regen

## Towing Coupler

E-Hitch w/ 1" pin  
(other options available)

## Tires

Front: 6.50 x 10

Back: 7.00— 15

## Controller

Curtis Programable

## Energy Source

80V Lithium-ion or 80V Lead-acid

## Charging Options

- On Board Charger
- EV Interface (used w/ on board charger)
- Standard Charger
- Fast Charge connection set-up

## Steer Axle

Heavy-Duty Harlan with 1 1/8" Kingpin

## Suspension

Front: Leaf spring w/ Shocks

Rear: Coil spring w/ Shocks

## Steering System

Hydrostatic

## Park Brake

Electric actuated

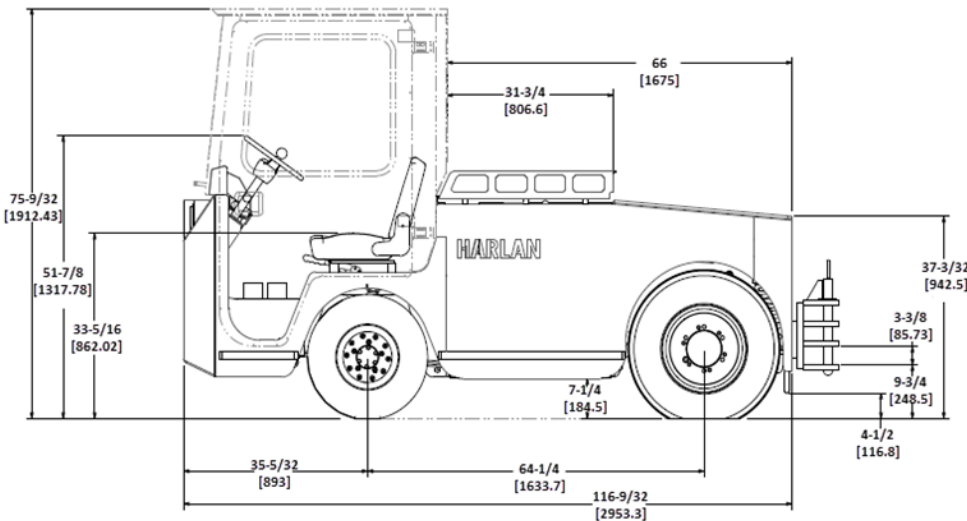

## DRAW BAR PULL

HLE45

4,500 lbs. (20kN)

HLE50

5,000 lbs. (22kN)

HLE60

6,000 lbs. (26.7kN)

HLEPB

Regional Jet up to 100K



27 Stanley Rd. Kansas City KS, 66115 USA 913.342.5650

telephone 800.255.4262 toll-free US 913.321.5802 FAX